

**Michael Tsapatsis (PI) and Prodromos Daoutidis (co-PI)  
Drs. Bahman Elyassi, Fernando Lima and Aparna Iyer (Presenter)  
Department of Chemical Engineering and Materials Science  
University of Minnesota**

**DE-FE0001322 Hydrogen Selective Exfoliated Zeolite Membranes**

**Proposal in response to Funding Opportunity NO. DE-PS26-08NT00699-01**

**Pre-combustion carbon capture technologies for coal-based gasification plants**

**Topic Area 1 – High-Temperature, High-Pressure Membranes**

**Total Project Funding: \$993,772 , DOE/Non-DOE Share: 793,775 /199,997**

**Period of Performance: 10/1/2009 to 9/30/2014**

# Objective

To develop a technically and economically viable membrane for H<sub>2</sub> separation from typical water-gas-shift (WGS) mixture feeds at high temperatures.

## Outline

- **Preparation of hydrogen selective membranes using zeolite nanosheets.**
- **Steam stability of layered zeolites (MCM-22, ITQ-1, RUB-24, Nu-6(2)).**
- **Modeling and optimization of IGCC plant with membrane reactor.**

# Layered zeolites with 6-MR pores

MCM-22 (Si/Al=40)

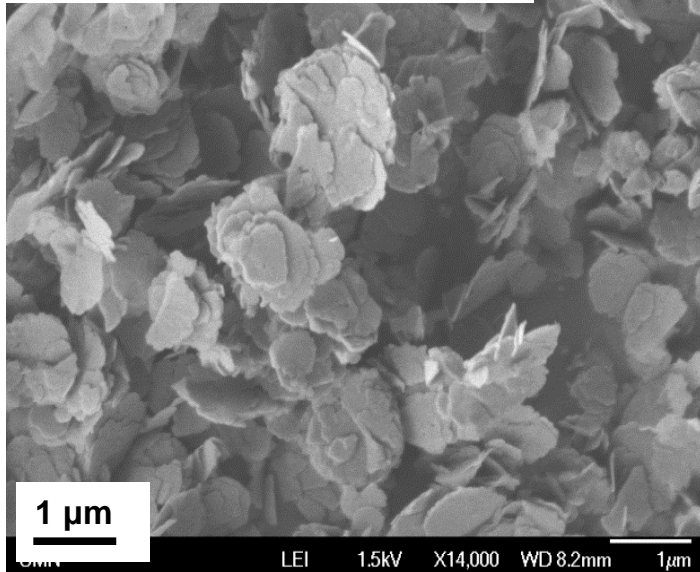

ITQ-1 (Si/Al=∞)

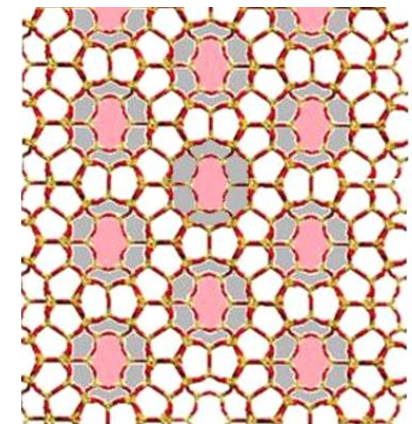
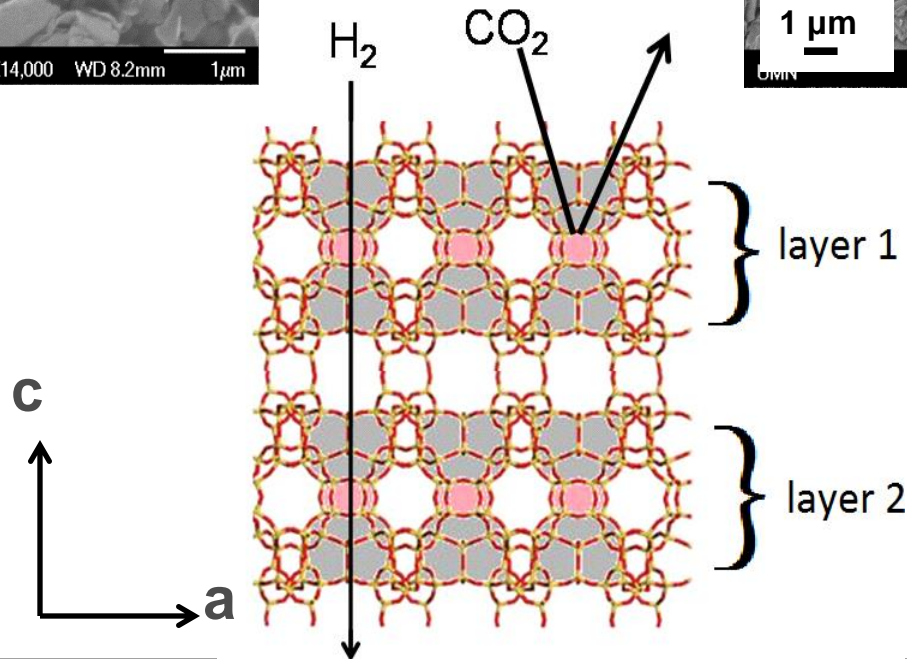
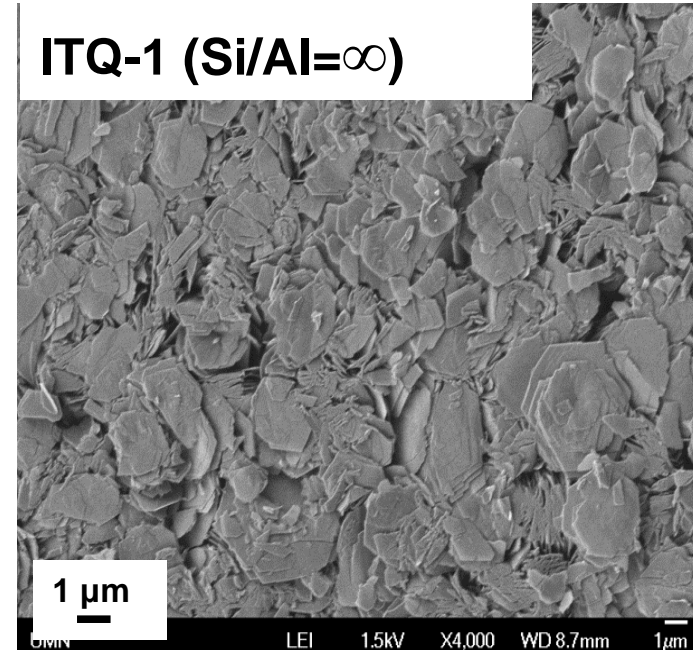

# Hierarchical manufacturing of zeolite membranes

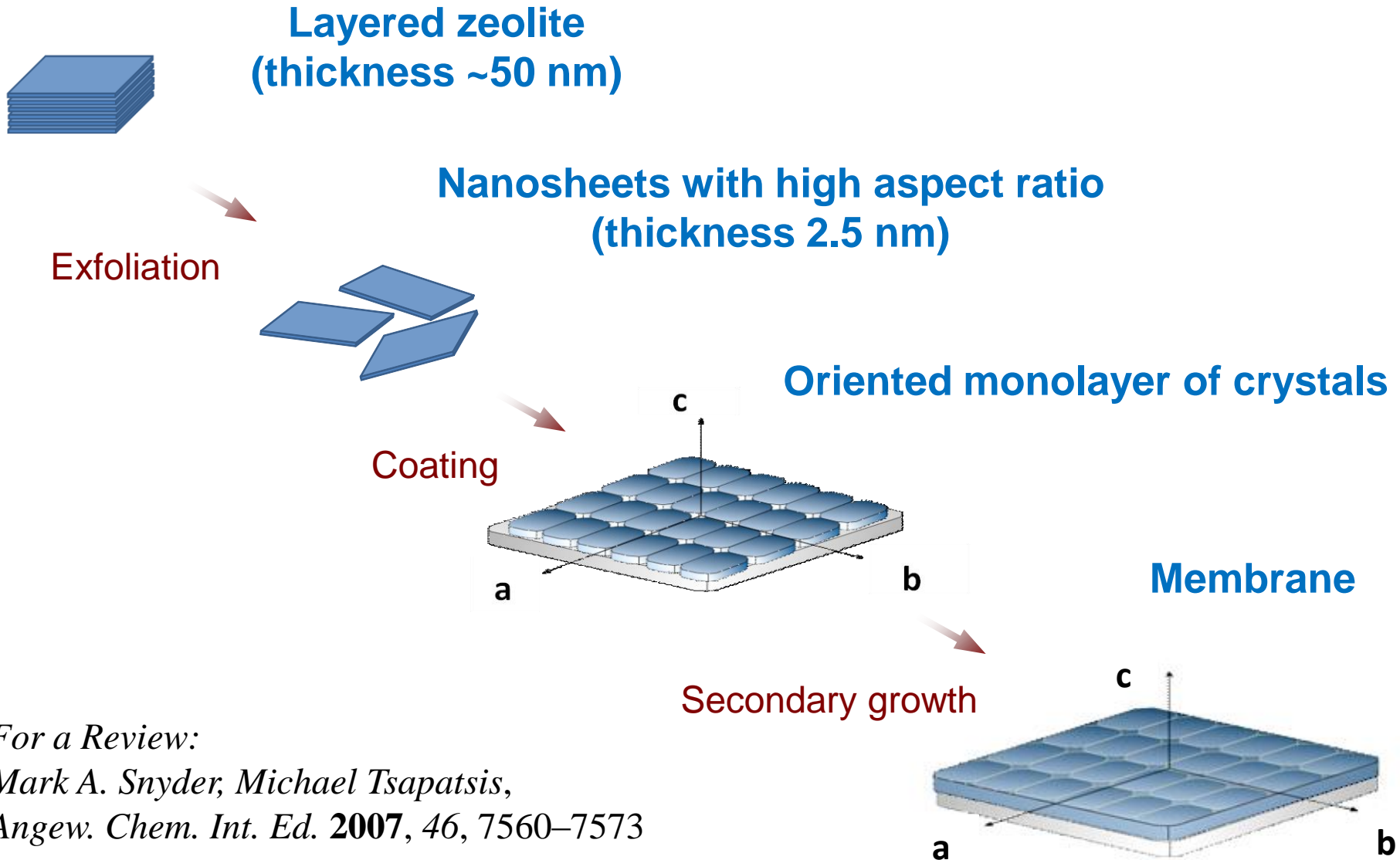

*For a Review:*

*Mark A. Snyder, Michael Tsapatsis,*

*Angew. Chem. Int. Ed.* **2007**, 46, 7560–7573

# Membrane preparation

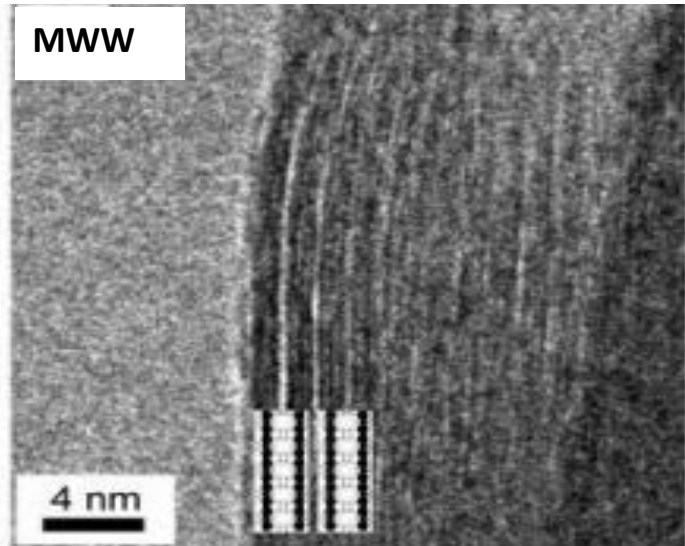

Swelling with CTAB

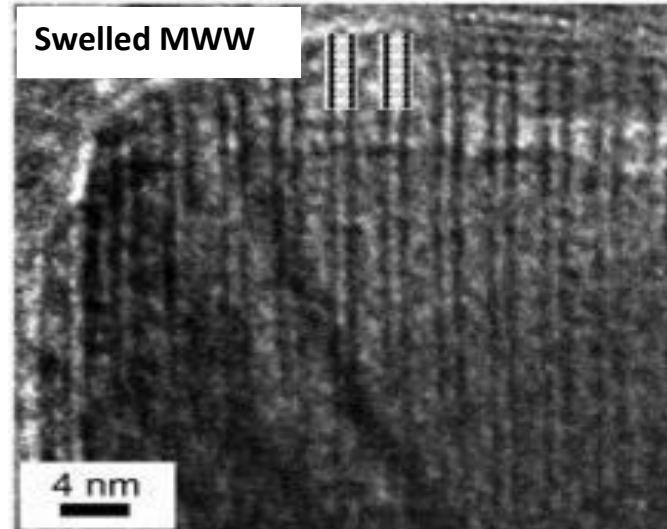
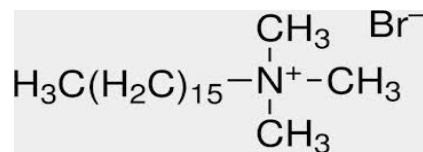

Exfoliation  
with  
polystyrene

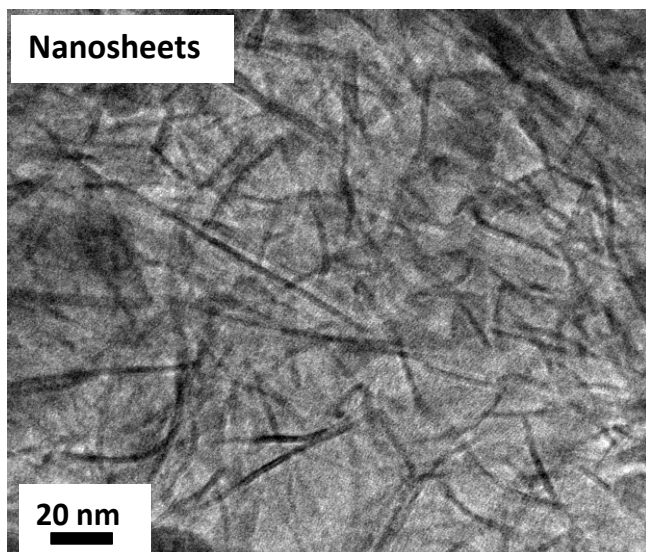

Dissolving  
nanocomposite  
in toluene,  
purification and  
filtration

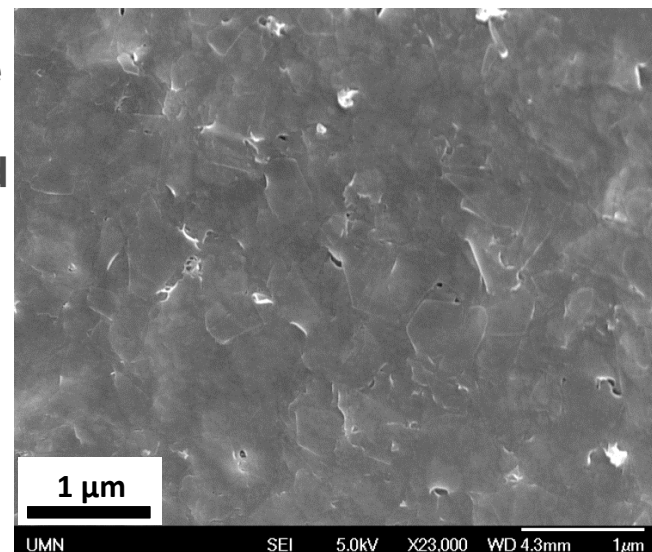

# Membrane preparation

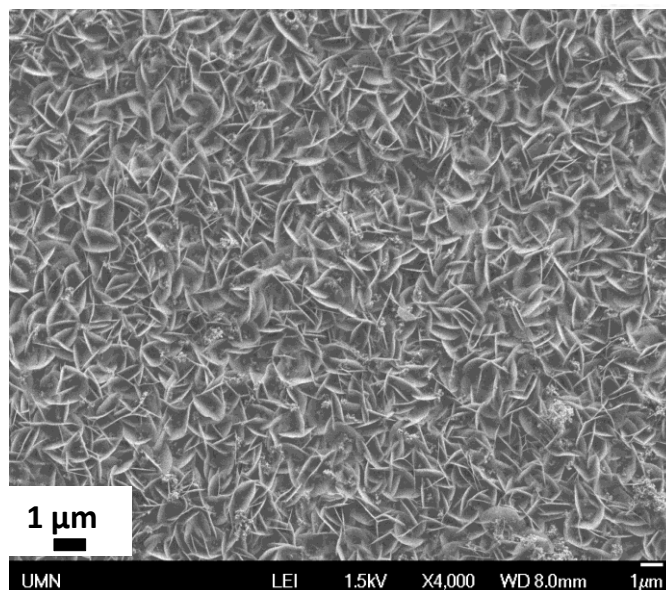

Secondary growth



Exfoliation  
with  
polystyrene

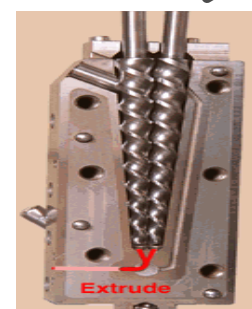

Nanosheets

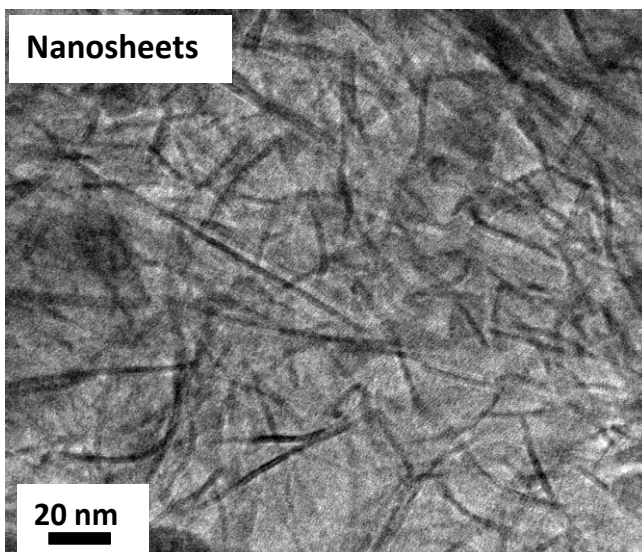

Dissolving  
nanocomposite  
in toluene,  
purification and  
filtration

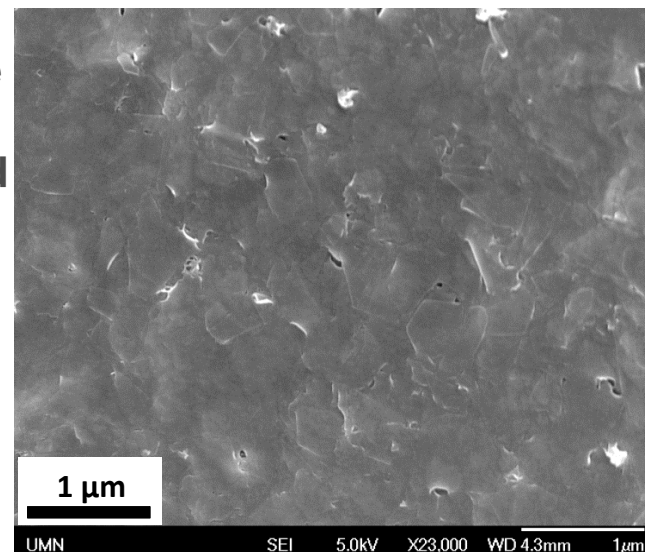

# Performance of an ITQ-1 Membrane

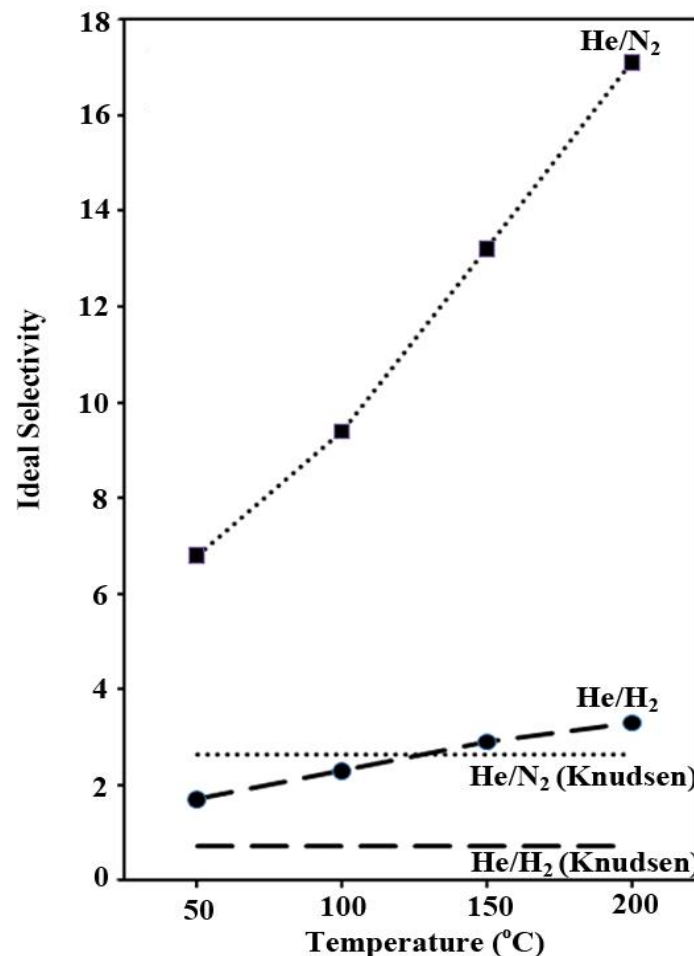
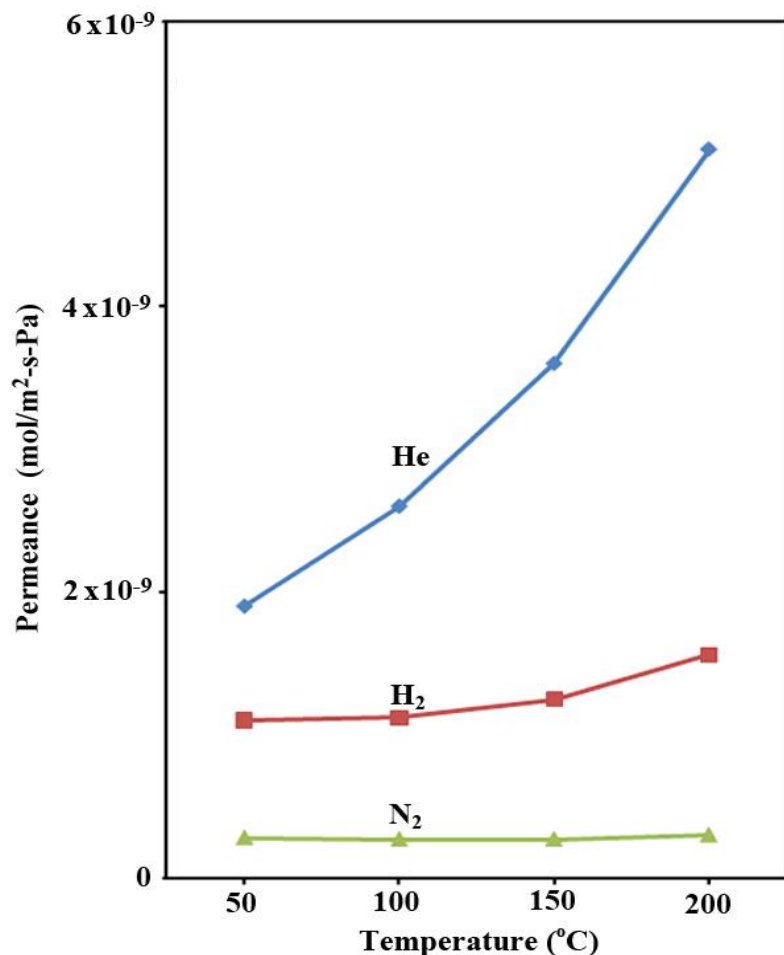

Varoon K., Zhang X., Elyassi B., Brewer D.D., Gettel M., Kumar S., Lee J.A., Maheshwari S., Mittal A., Sung c., Cococcioni M., Francis L.F., McCormick A.V., Mkhoyan K.A., Tsapatsis M., Science 334 (2011) 72–75.

# Steaming conditions for ITQ-1 and MCM-22

- Steaming conditions:
- Temperature: 350°C
- Pressure: 10 bar (95% steam, 5% nitrogen)
- Samples were analyzed in 21 days intervals for 84 days



# Stability of ITQ-1 and SiCl<sub>4</sub>-treated ITQ-1

## Treating ITQ-1 with SiCl<sub>4</sub> to heal structural defects

Flow of nitrogen saturated with SiCl<sub>4</sub> vapor at room temperature

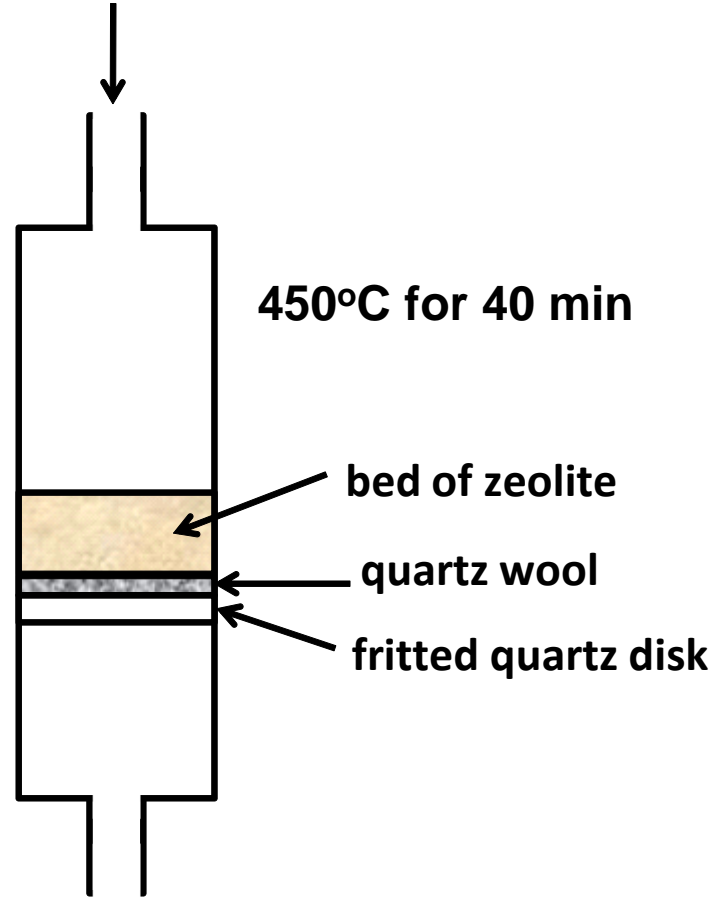
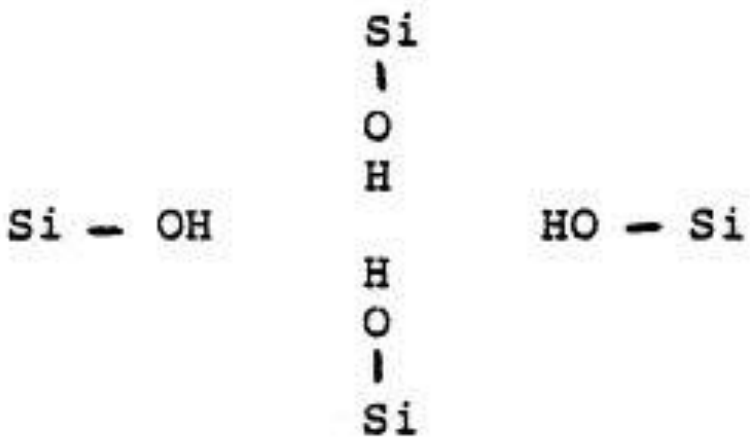

Beyer et. al., J . Chem. Soc., Faraday Trans. 1, 1985, 81, 2889-2901.

# Stability of ITQ-1 and SiCl<sub>4</sub>-treated ITQ-1

## Treating ITQ-1 with SiCl<sub>4</sub> to heal structural defects

Flow of nitrogen saturated with SiCl<sub>4</sub> vapor at room temperature

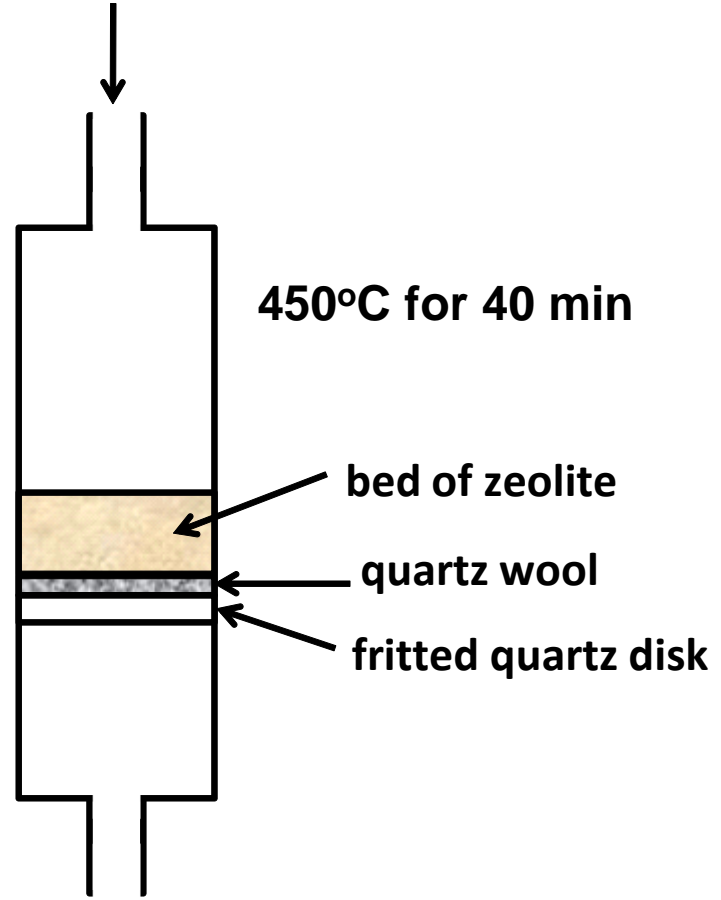
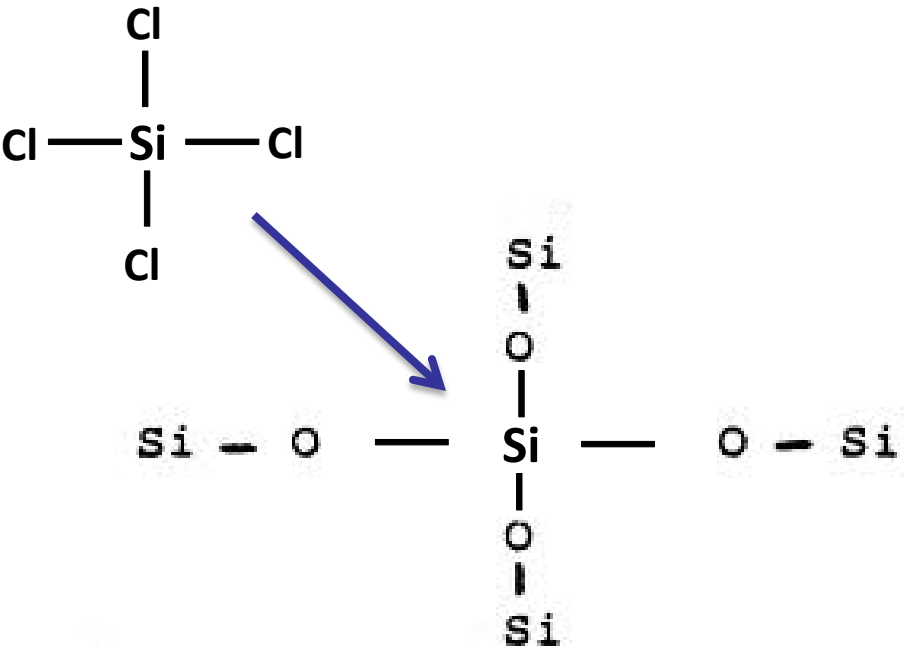

Beyer et. al., J . Chem. Soc., Faraday Trans. 1, 1985, 81, 2889-2901.

# XRD of ITQ-1 and ITQ-1 treated with $\text{SiCl}_4$ at $350^\circ\text{C}$

- SiCl<sub>4</sub> treatment is effective in improving the hydrothermal stability of ITQ-1

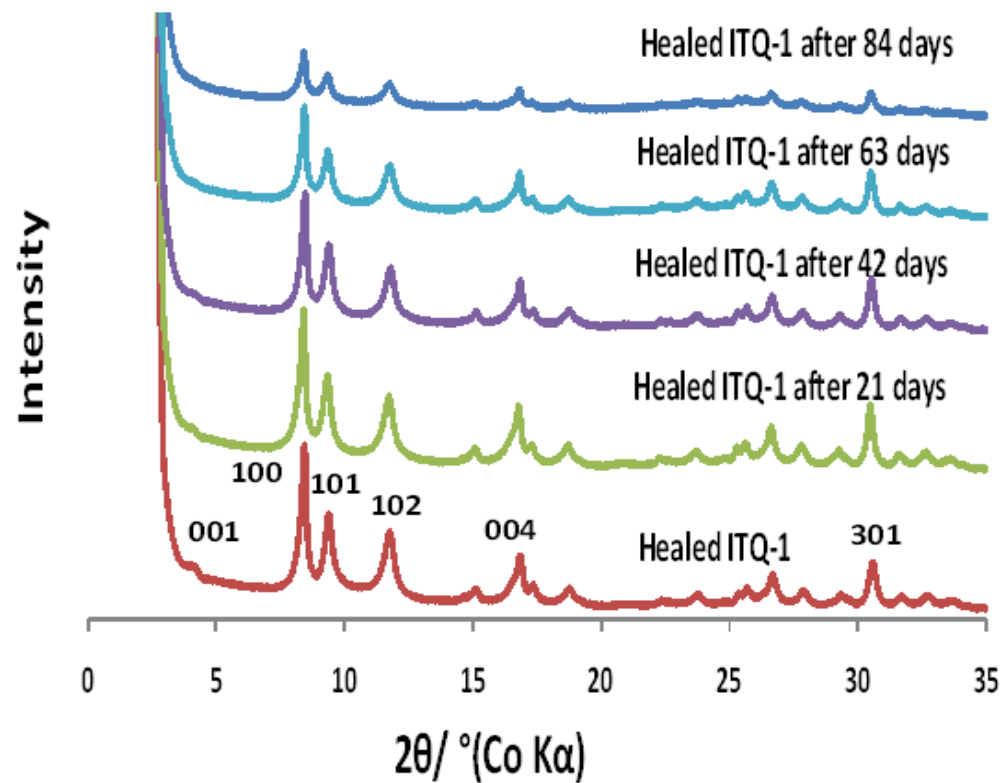
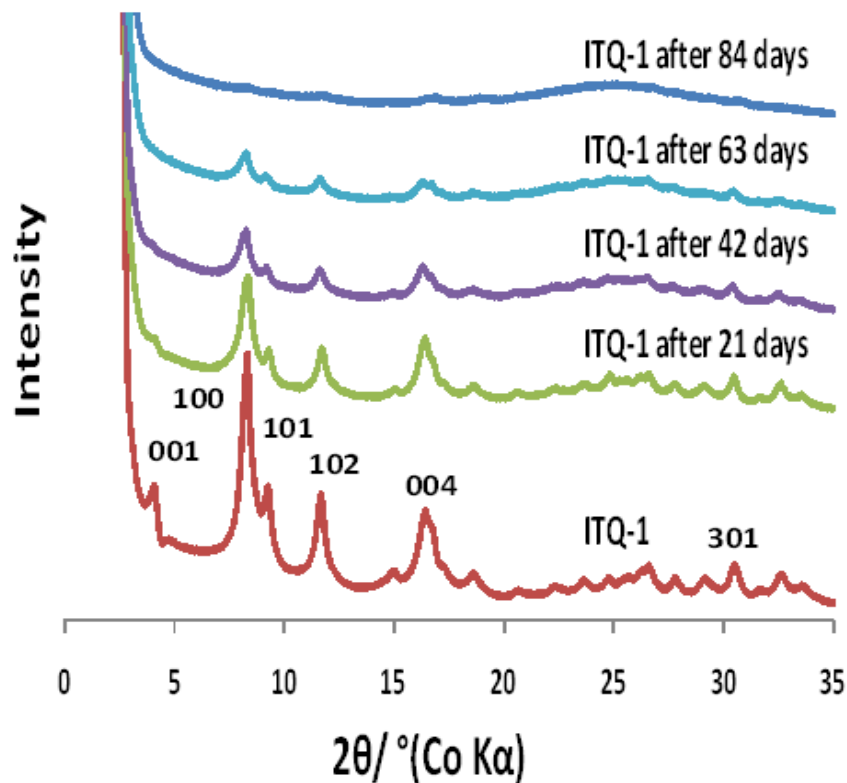

# TEM images of ITQ-1 before and after 84 days of steaming

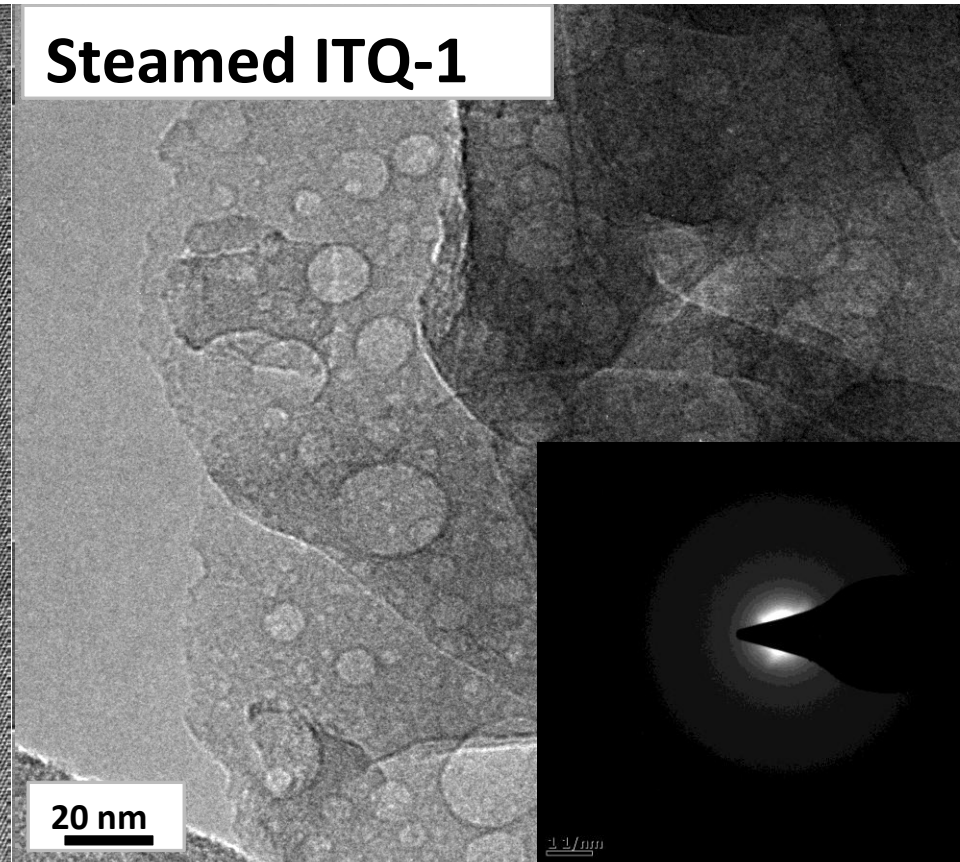
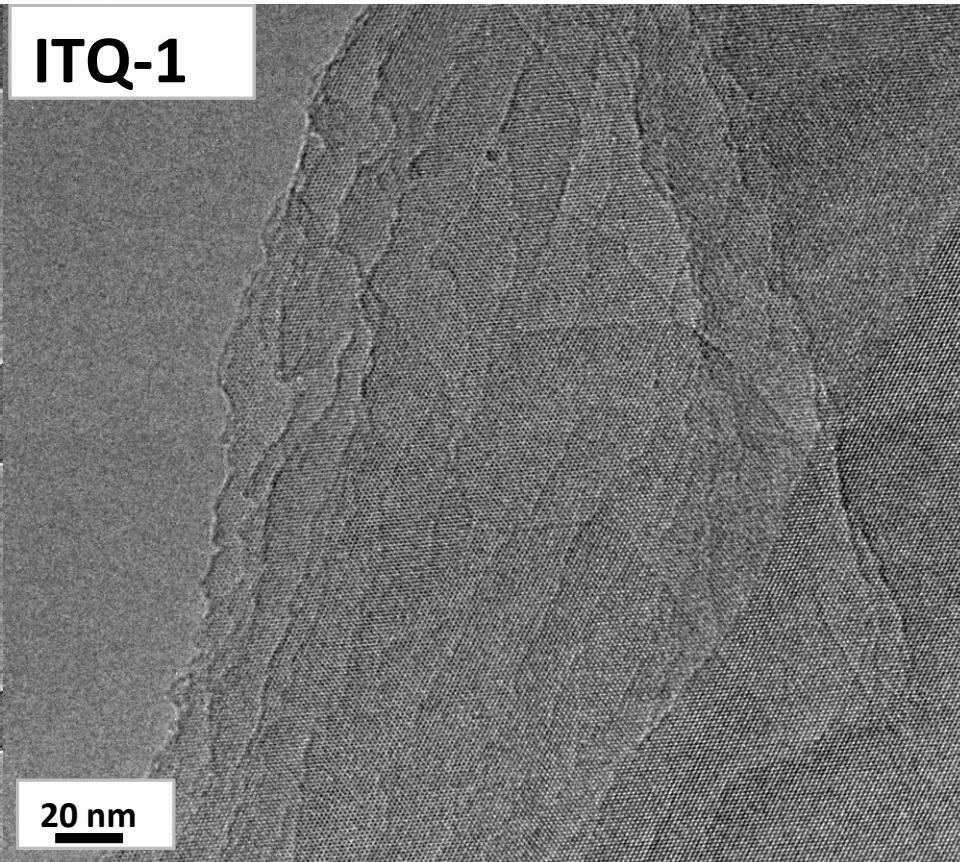

# TEM images of **healed ITQ-1** before and after 84 days of steaming

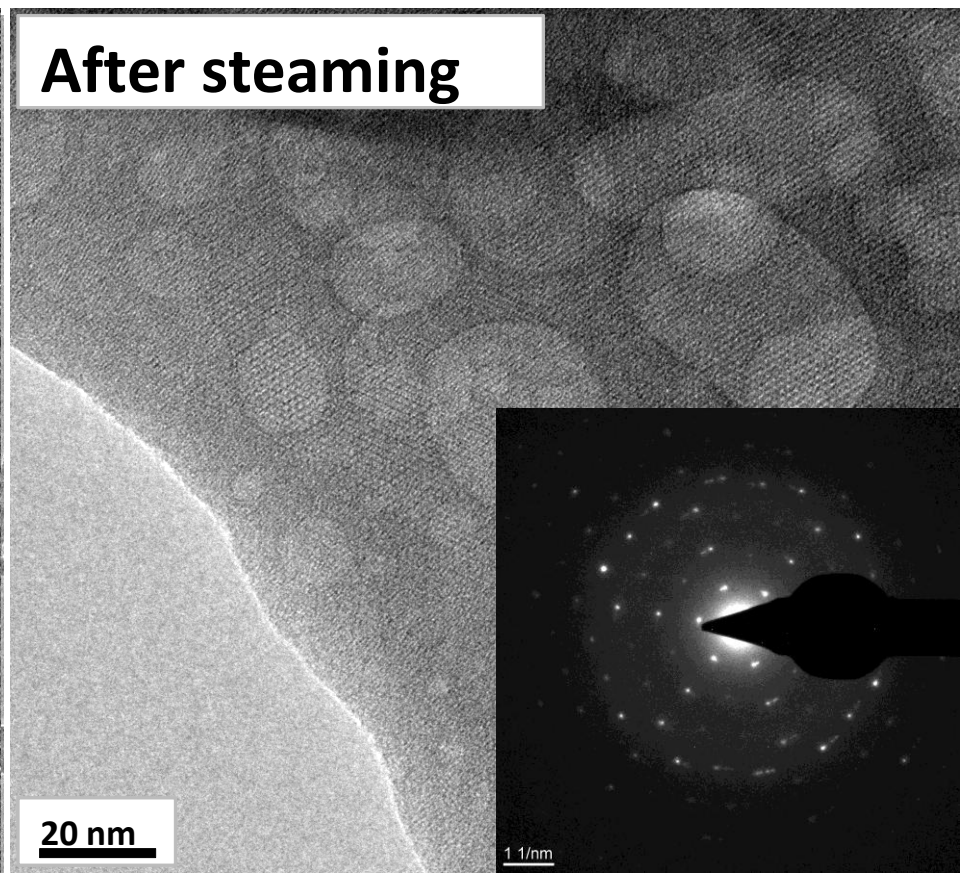
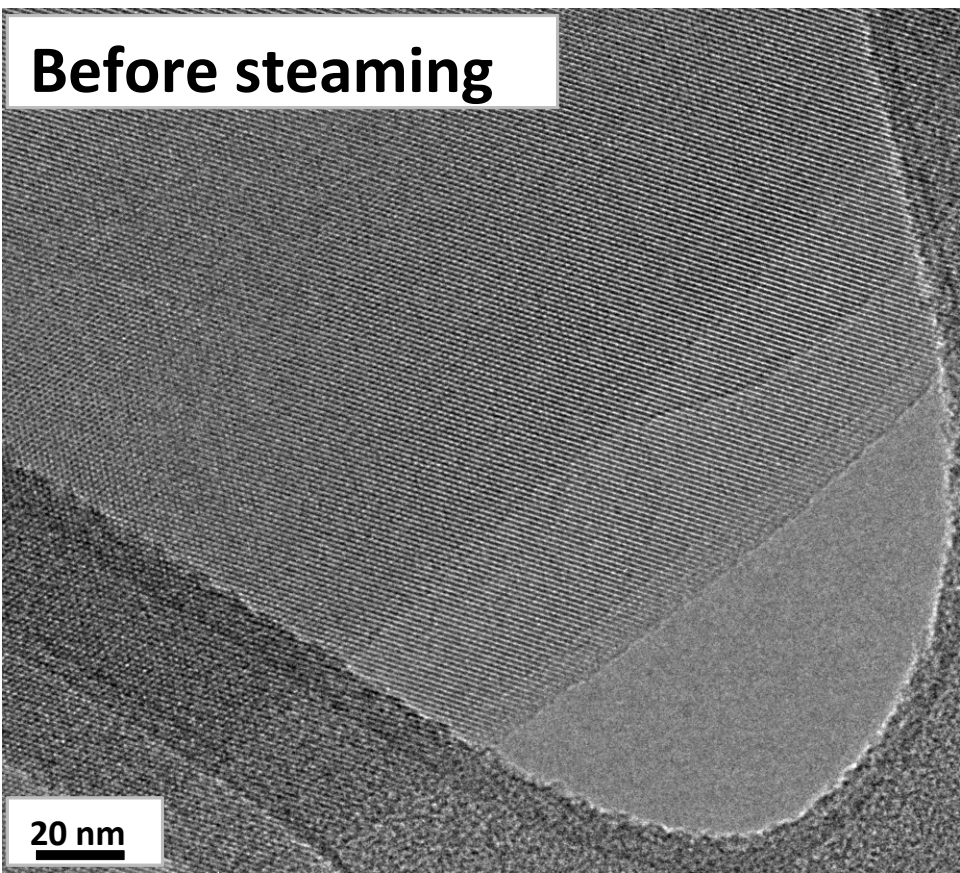

# $^{29}\text{Si}$ MAS NMR of ITQ-1 and $\text{SiCl}_4$ treated ITQ-1 before and after steaming for 84 days at $350^\circ\text{C}$

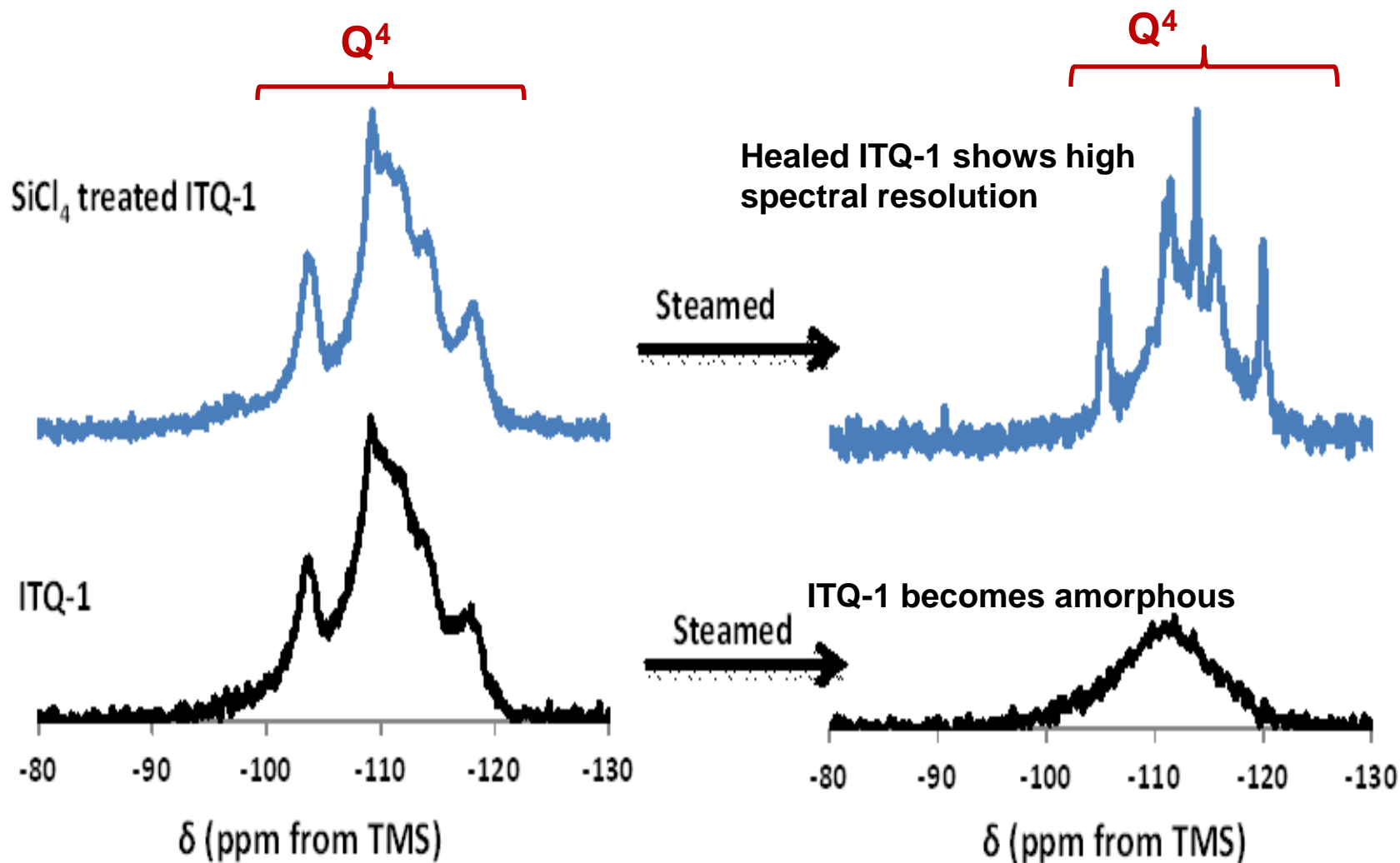

# Steam stability of MCM-22 (Si/Al=40)

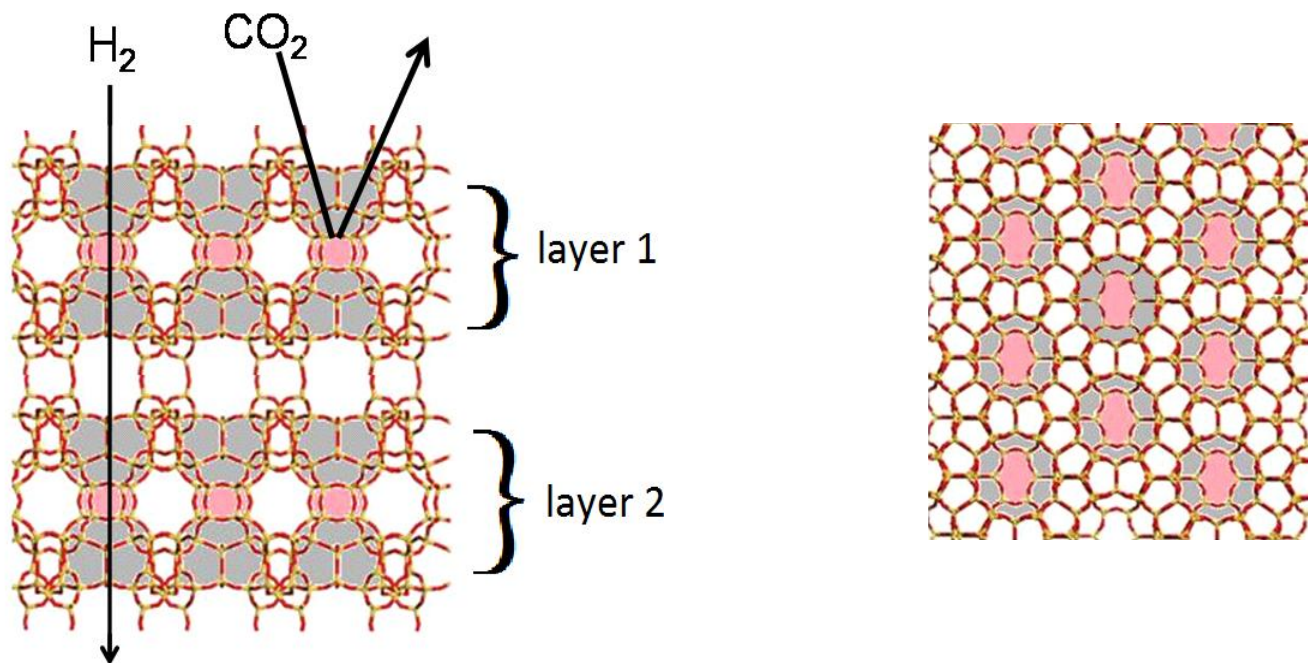

# XRD of MCM-22 steam treated at 350°C

- MCM-22 keeps its crystallinity.
- No change in crystal morphology was seen in the SEM pictures.

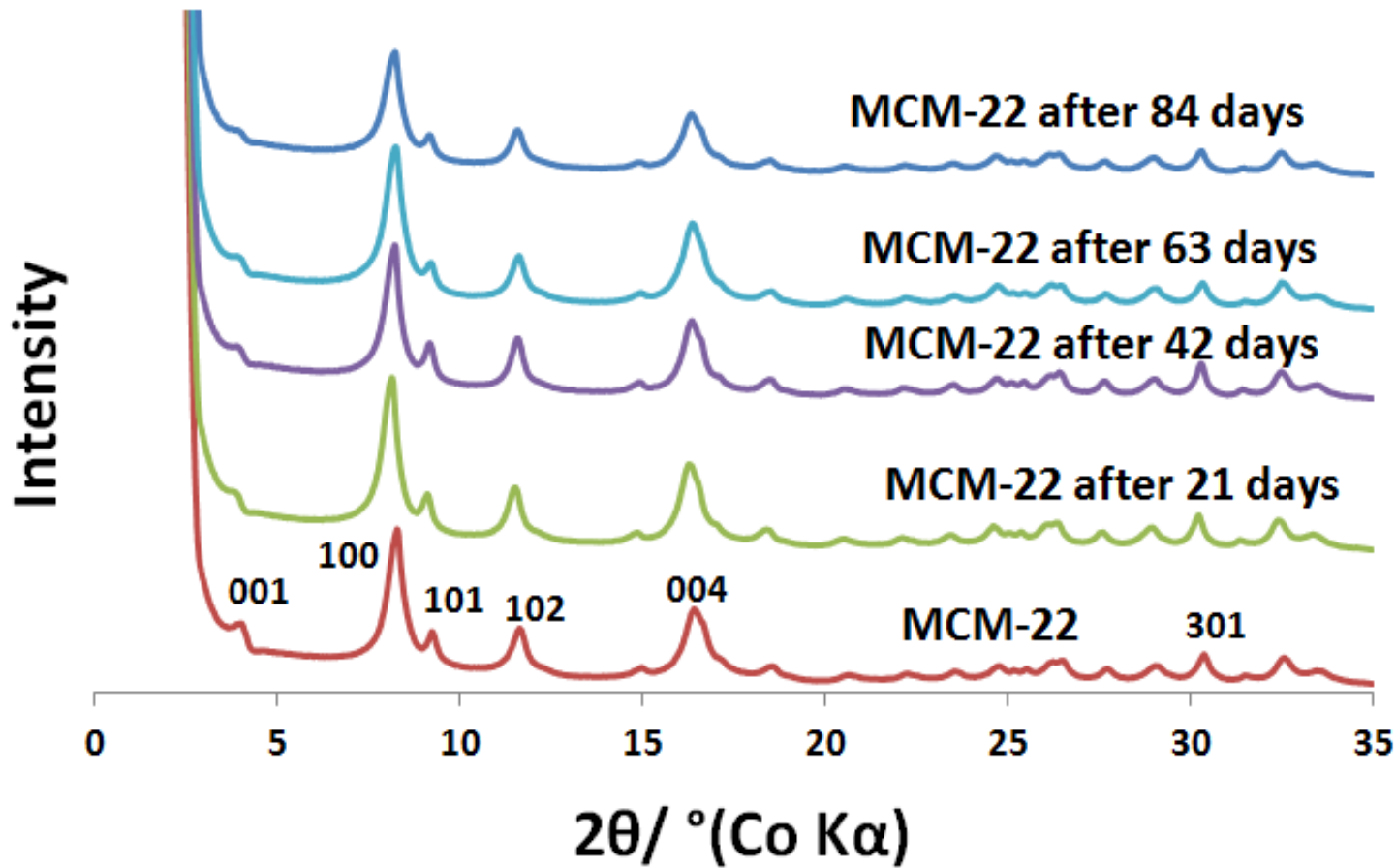



# TEM images of MCM-22 before and after 84 days of steaming

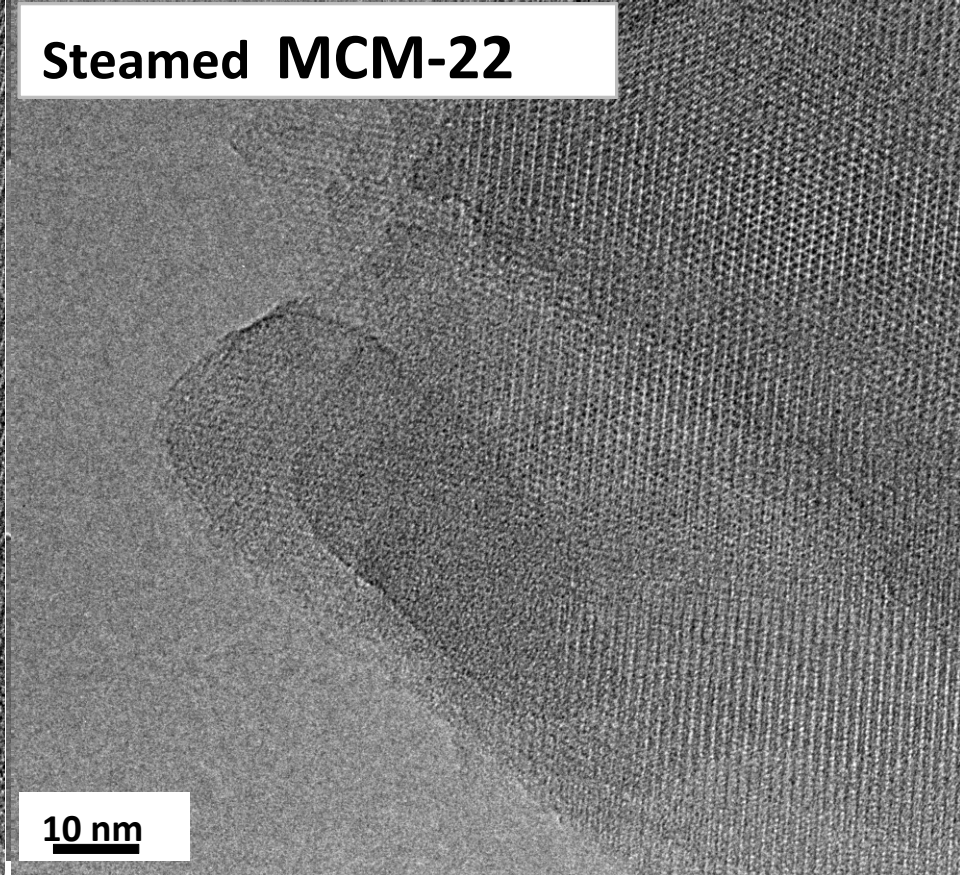
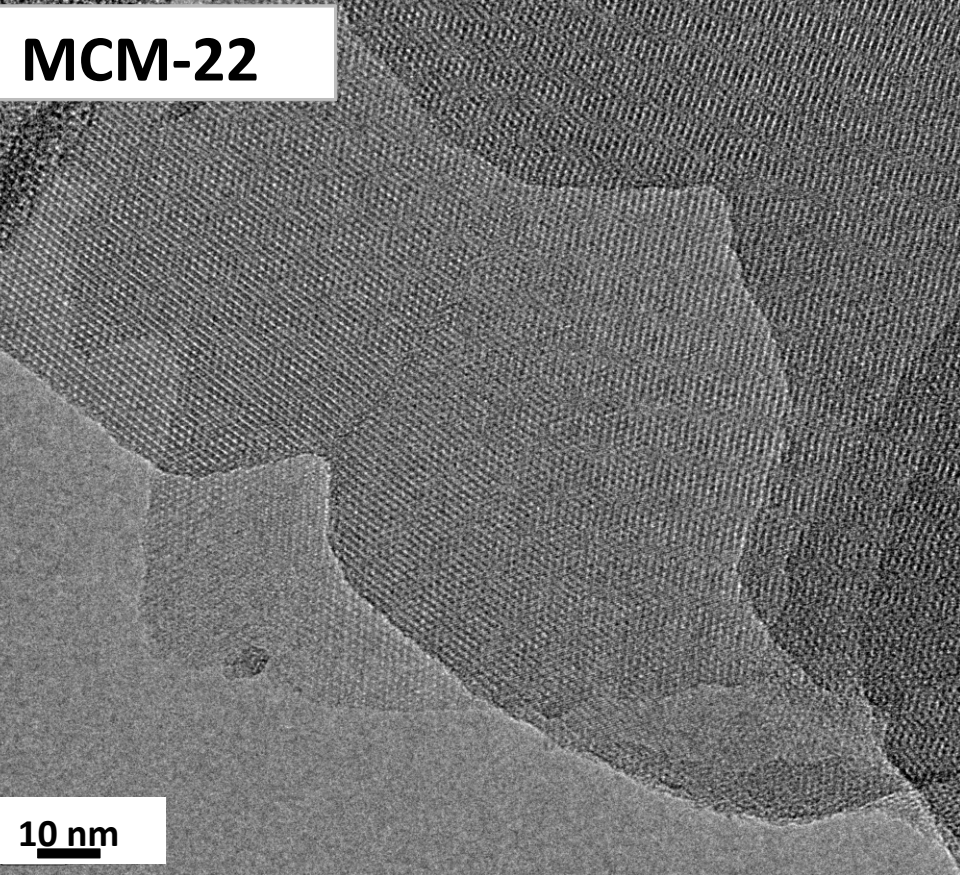

# $^{29}\text{Si}$ and CP/MAS NMR of MCM-22, before and after steaming at 350°C for 84 days

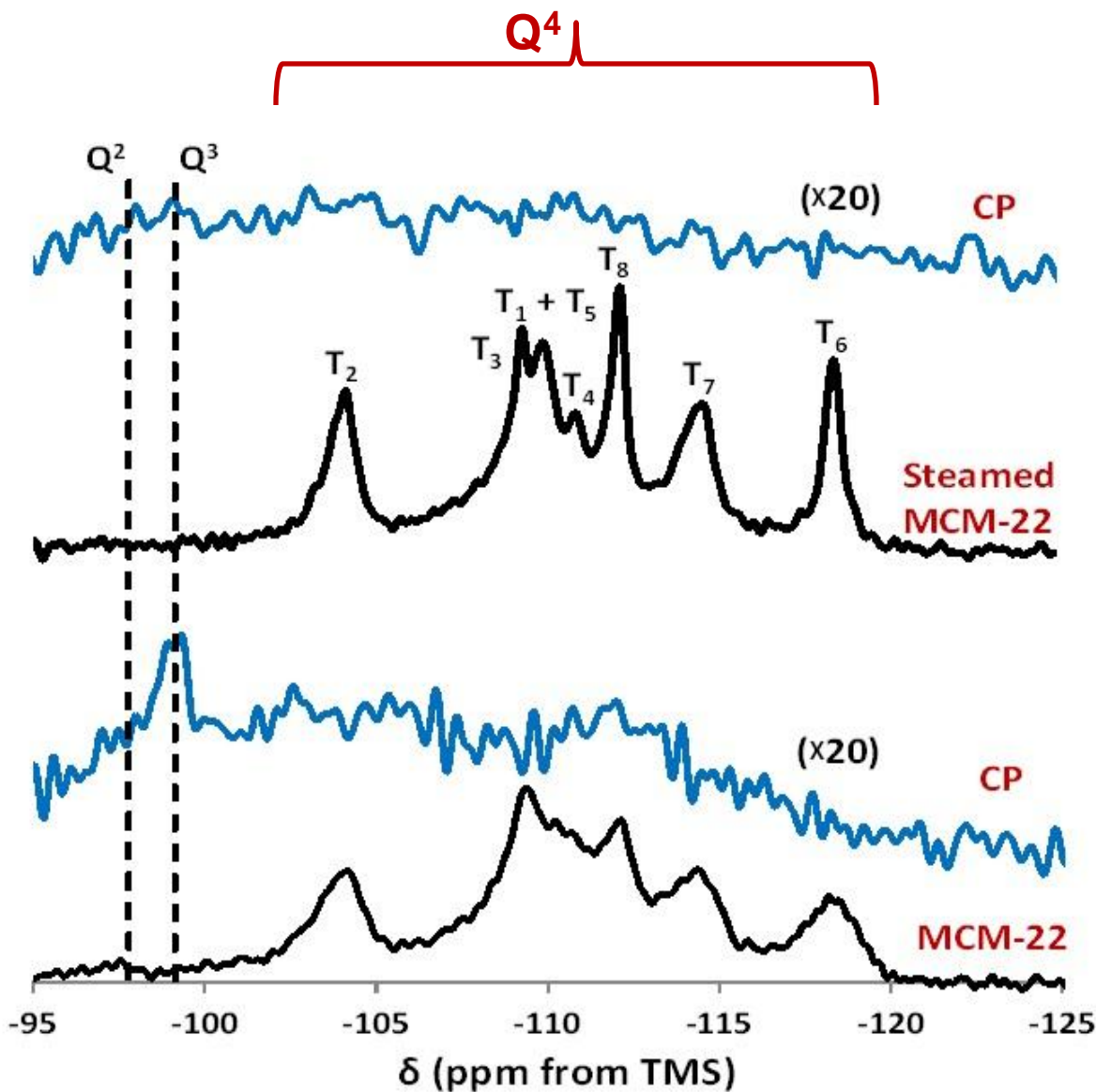

- Higher spectral resolution can be seen after hydrothermal treatment.
- Intensity reduction at -97 and -99 ppm (defect sites).

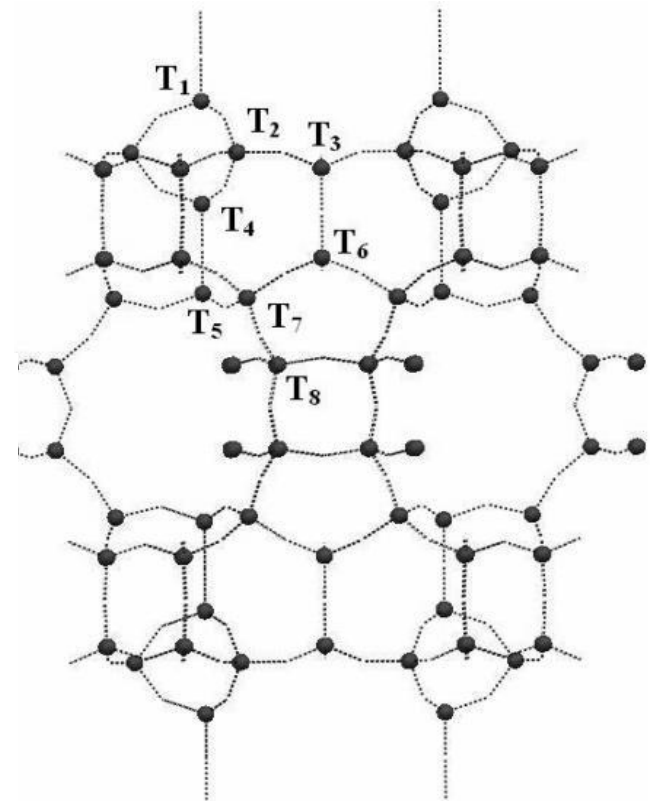

$$\sigma = -0.6192\theta - 18.68$$

G. Engelhardt, R. Radeglia, Chem. Phys. Lett. 108 (1984) 271-274.

# Effect of steaming on textural properties

	Before steaming			After steaming for 84 days		
	$S_{\text{BET}}^{\text{a}}$ ( $\text{m}^2/\text{g}$ )	$V_{\text{micro}}^{\text{b}}$ ( $\text{cm}^3/\text{g}$ )	$V_{\text{micro}}^{\text{c}}$ ( $\text{cm}^3/\text{g}$ )	$S_{\text{BET}}^{\text{a}}$ ( $\text{m}^2/\text{g}$ )	$V_{\text{micro}}^{\text{b}}$ ( $\text{cm}^3/\text{g}$ )	$V_{\text{micro}}^{\text{c}}$ ( $\text{cm}^3/\text{g}$ )
<b>MCM-22</b>	490	0.163	0.198	340	0.113	0.133
<b>ITQ-1-900</b>	402	0.138	0.186	13	0	0
<b>ITQ-1-H900</b>	470	0.160	0.195	110	0.027	0.034
<b>ITQ-1-580</b>	550	0.182	0.254	158	0.048	0.069
<b>ITQ-1-H580</b>	521	0.181	0.239	308	0.103	0.142

<sup>a</sup> BET surface area from  $\text{N}_2$  adsorption isotherm.

<sup>b</sup> Micropore volume from t-method using  $\text{N}_2$  adsorption isotherm.

<sup>c</sup> Micropore volume using the NLDFT kernel “Ar at 87 K zeolites- silica, cylindrical pore model”.

# XRD of patterns of Nu-6(2) and RUB-24 zeolites: Steamed at 350°C and 10 bar (35% H<sub>2</sub>O in N<sub>2</sub>) for 6 months

## Nu-6(2)

## RUB-24

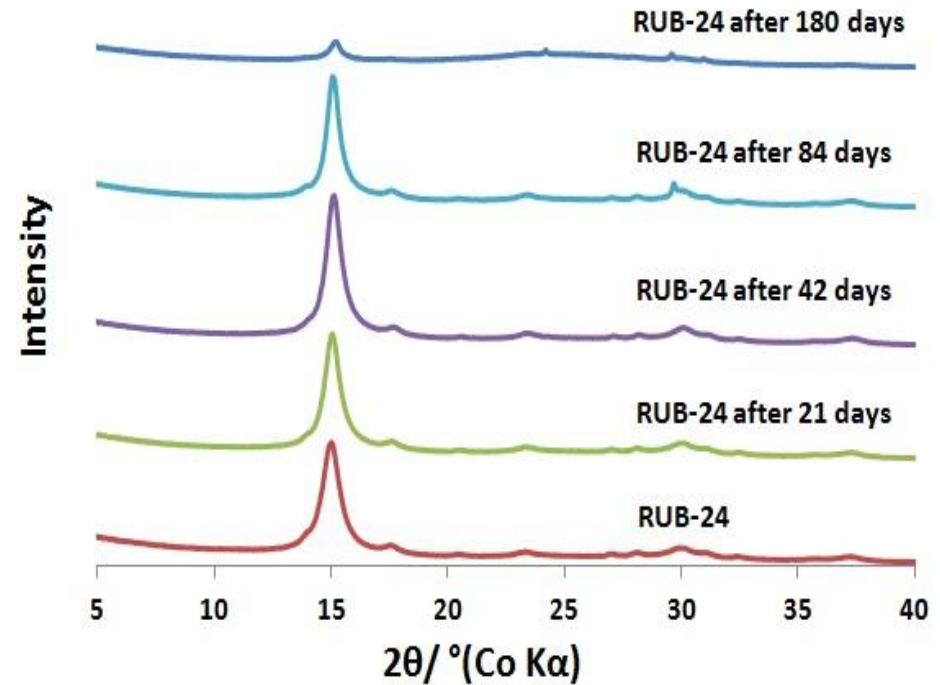
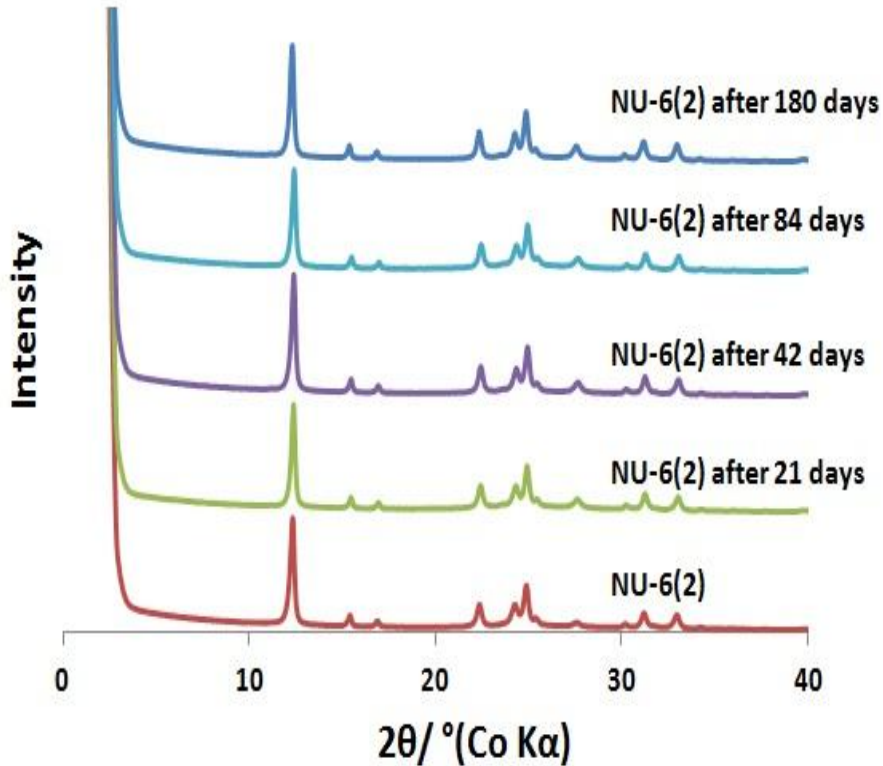

# Summary of stability analysis & future work

- **Achievements**
  - **Systematic studies on the long-term steam stability of zeolites: MCM-22, ITQ-1, NU-6(2), and RUB-24 were completed.**
  - **Healing of defects in the ITQ-1 crystal enhanced its steam stability.**
  - **NU-6(2) preserved its crystallinity after 6 months of steaming (35% H<sub>2</sub>O, 65% N<sub>2</sub>) at 350°C.**
  - **Permeation cell construction and its sealing evaluation at high temperatures.**
- **Future Work**
  - **Study of membranes' performance at high temperatures and under steaming.**

# Systems Modeling: Objectives and Approach

- Work done by Dr. Fernando Lima and Prof. Prodromos Daoutidis (UMN)
- Develop a WGS membrane reactor (MR) model
- Integrate MR model into IGCC system model
- Analyze effect of reactor design and membrane characteristics on integrated plant performance
  - achieve DOE R&D target goal of 90% CO<sub>2</sub> capture <sup>(1),(2)</sup>
  - satisfy stream constraints for CO<sub>2</sub> capture and gas turbine fuel (H<sub>2</sub> rich)<sup>(3)</sup>
  - quantify process efficiency and power generation
- Perform optimization studies and techno-economic analysis for integrated plant
- Received input from DOE/NETL personnel (John Marano and Jared Ciferno)

(1) Marano, Report to DOE/NETL (2010)

(2) Marano and Ciferno, *Energy Procedia* **1**, 361-368 (2009)

(3) Lima et al., *Ind. Eng. Chem. Res.* **51**, 5480-5489 (2012)

# MR Modeling Assumptions and Simulation Set Up

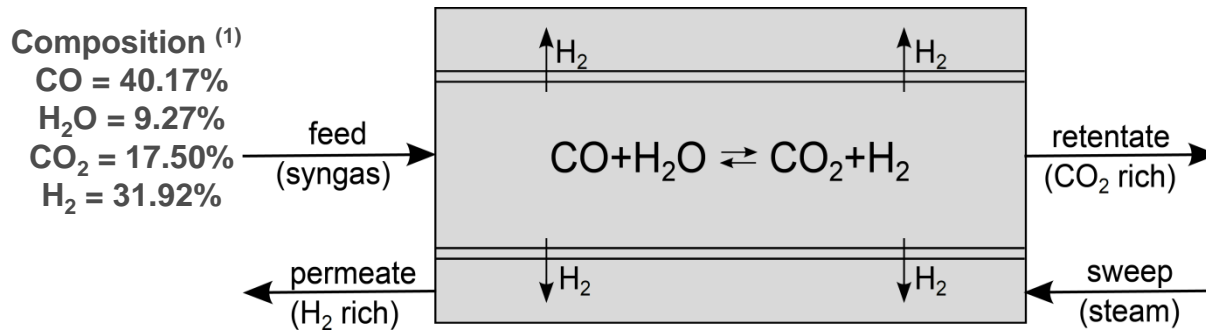

- **Assumptions**

- 1-dimensional shell and tube reactor
- catalyst packed in tube side
- thin membrane layer placed on surface of tube wall
- sweep gas flows in shell side
- plug-flow operation
- constant temperature and pressure
- steady-state operation
- ideal gas law

- **Flow configurations**

- ◆ co-current
- ❖ counter-current

- **Simulation conditions**

- ◆ catalyst type and reaction rate <sup>(2)</sup>
- ◆ reactor dimensions (lab)
- ◆ consistent with IGCC specifications

- **Model used to perform simulation and optimization studies <sup>(3)</sup>**

(1) Jillson et al., *J. Proc. Cont.* **19**, 1470-1485 (2009)

(2) Choi and Stenger, *J. Power Sources* **124**, 432-439 (2003)

(3) Lima et al., *Ind. Eng. Chem. Res.* **51**, 5480-5489 (2012)

# Integration of MR into IGCC Plant (MATLAB)

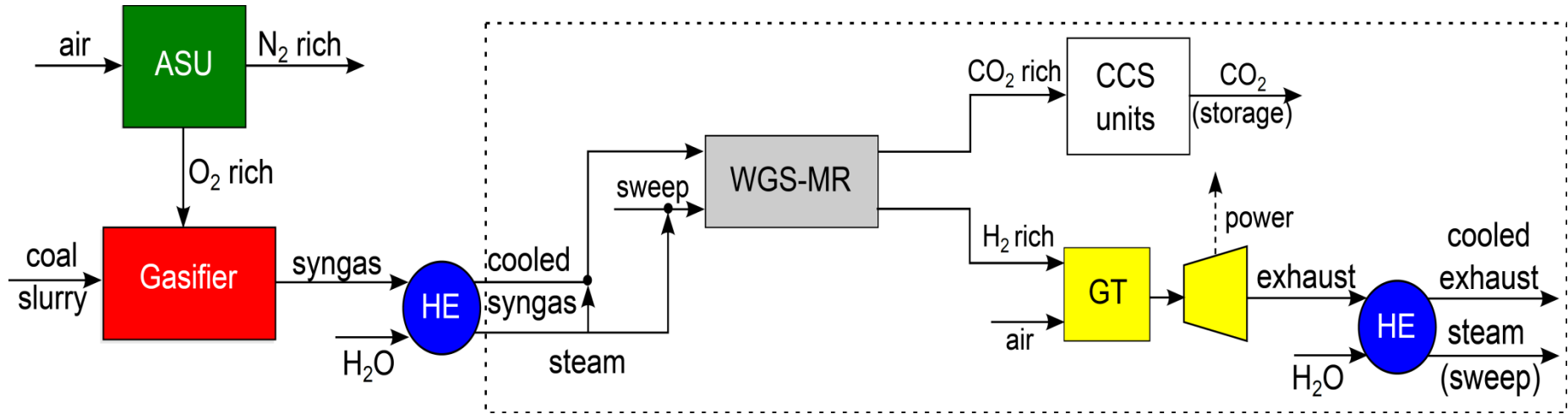

- Scale up MR model at steady state
- MR integration downstream of gasifier <sup>(1),(2)</sup>
- Effect on turbines/heat exchangers
- Steam integration for MR utilization
- Simulation studies performed
- Novel optimization problem formulation
  - ◆ minimize cost of membrane as function of surface area
  - ◆ determine optimal operating point that satisfies all constraints

(1) Marano and Ciferno, *Energy Procedia* **1**, 361-368 (2009)

(2) Bracht et al., *Energy Convers. Mgmt* **38**, S159-164 (1997)



# IGCC-MR Optimization Results: Different Membrane Characteristics

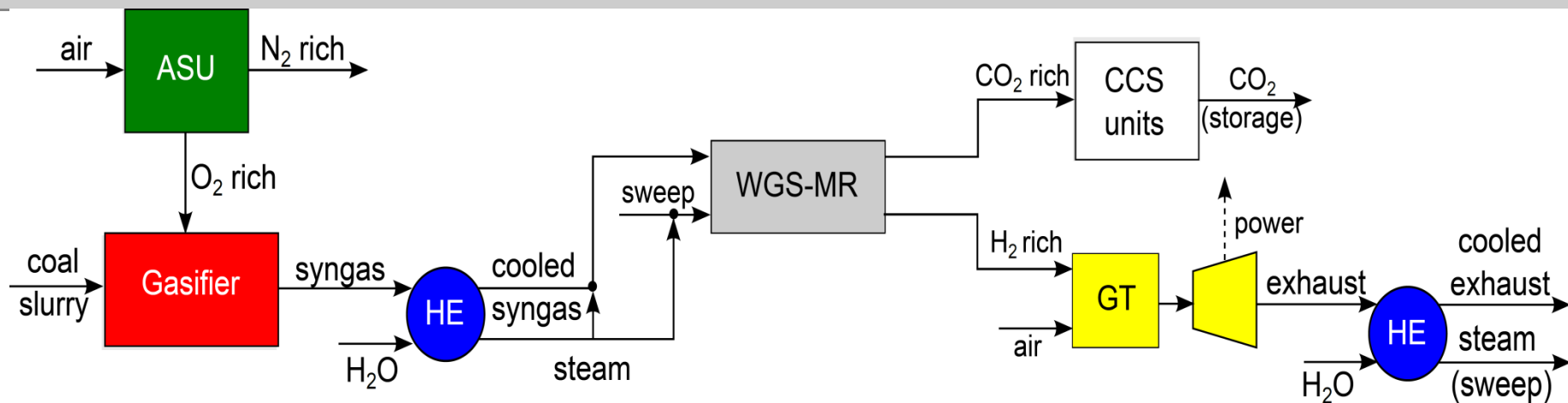

IGCC Performance Variable	Nominal ( $S_{H_2/all} = 1000,$ $Q_{H_2} = 0.2$ )	Nominal Optimal	Case 1 ( $S_{H_2/all} = 1000,$ $Q_{H_2} = 0.1$ )	Case 2 ( $S_{H_2/all} = 100,$ $Q_{H_2} = 0.2$ )
$A_m =$ membrane area [m <sup>2</sup> ]	6800	4989	7271	4739
$C_{CO_2} = \frac{\text{carbon captured}}{\text{carbon in feed}}$ [%]	98.54	99.02	99.28	91.13
$\eta = \frac{\text{power generated}}{\text{HHV energy in coal}}$ [%]	47.96	47.55	46.96	47.63
$W =$ power generated [MW]	614.07	617.60	615.00	618.41

$Q_{H_2} = \text{mol}/(\text{s} \cdot \text{m}^2 \cdot \text{atm})$

# IGCC-MR Differential Cost Analysis

- Cost comparison between IGCC with and without MR
- Same amount of coal and power generation ( $\approx 615$  MW)
- Cost differences
  - ◆ larger ASU (IGCC) <sup>(1)</sup>: \$291.01 million/30 years
  - ◆ steam and gas turbines differences (IGCC) <sup>(1)</sup>: \$41.53 million/30 years
  - ◆ extra heat exchangers (IGCC-MR) <sup>(2)</sup>: \$3.78 million/30 years
  - ◆ added MR with  $A_m = 5000$  m<sup>2</sup> (IGCC-MR):  $\approx$  \$5-50 million/lifetime

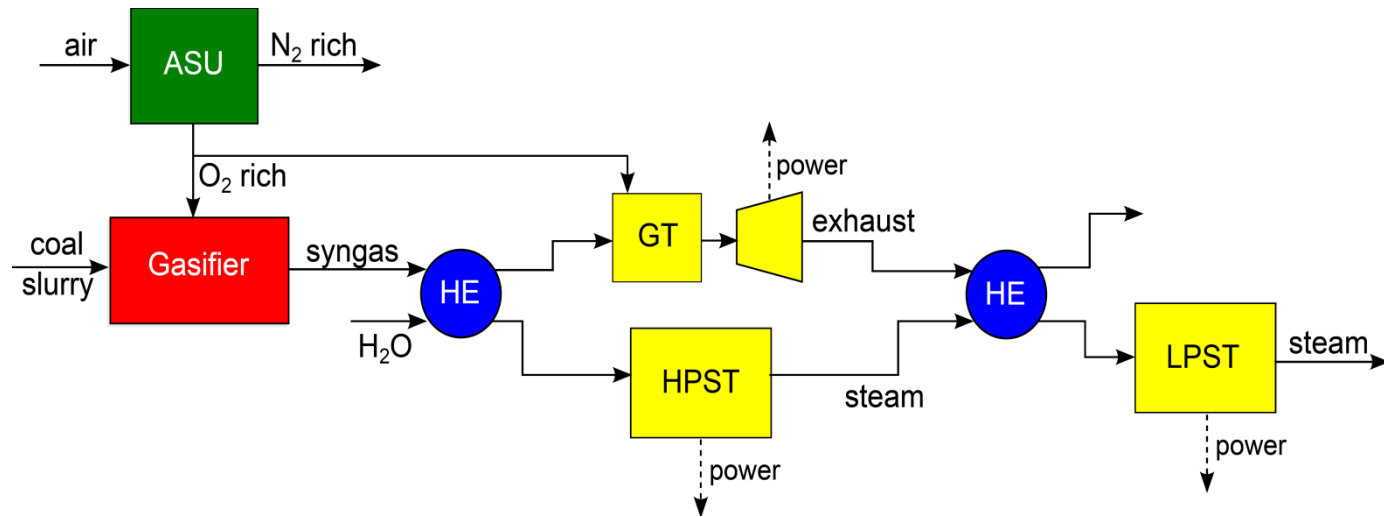

(1) Haslbeck et al., **Baseline Report to DOE/NETL** (2010)

(2) Turton et al., **Analysis, Synthesis and Design of Chemical Processes** (2012)

# IGCC-MR Differential Cost Analysis

- Cost comparison between IGCC with and without MR
- Same amount of coal and power generation ( $\approx 615$  MW)
- Cost differences
  - ◆ larger ASU (IGCC) <sup>(1)</sup>: \$291.01 million/30 years
  - ◆ steam and gas turbines differences (IGCC) <sup>(1)</sup>: \$41.53 million/30 years
  - ◆ extra heat exchangers (IGCC-MR) <sup>(2)</sup>: \$3.78 million/30 years
  - ◆ added MR with  $A_m = 5000$  m<sup>2</sup> (IGCC-MR):  $\approx$  \$5-50 million/lifetime

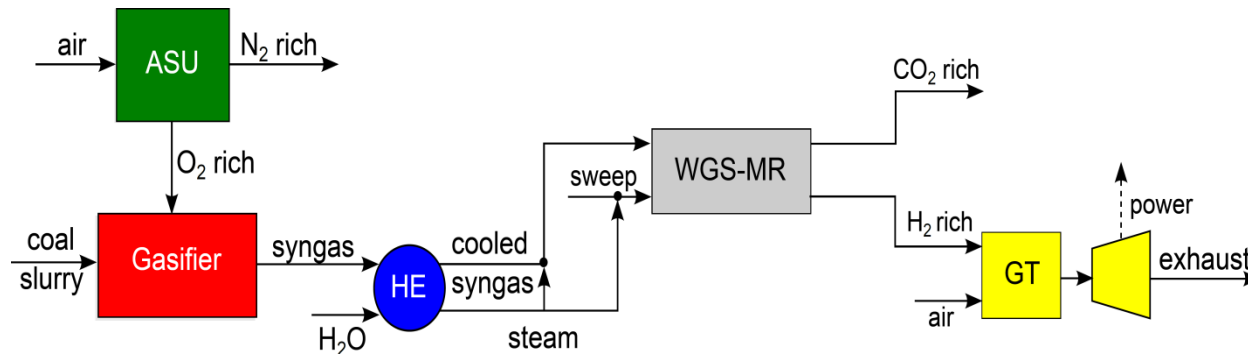

(1) Haslbeck et al., **Baseline Report to DOE/NETL** (2010)

(2) Turton et al., **Analysis, Synthesis and Design of Chemical Processes** (2012)

# IGCC-MR Differential Cost Analysis

- Cost comparison between IGCC with and without MR
- Same amount of coal and power generation ( $\approx 615$  MW)
- Cost differences
  - ◆ larger ASU (IGCC) <sup>(1)</sup>: \$291.01 million/30 years
  - ◆ steam and gas turbines differences (IGCC) <sup>(1)</sup>: \$41.53 million/30 years
  - ◆ extra heat exchangers (IGCC-MR) <sup>(2)</sup>: \$3.78 million/30 years
  - ◆ added MR with  $A_m = 5000$  m<sup>2</sup> (IGCC-MR):  $\approx$  \$5-50 million/lifetime
- Calculate MR cost to break even in a 30 year period
- Results based on present value of annuity calculation

Lifetime [year]	Cost [\$/m <sup>2</sup> ]
1	5,840
2	11,680
3	17,520

(1) Haslbeck et al., **Baseline Report to DOE/NETL** (2010)

(2) Turton et al., **Analysis, Synthesis and Design of Chemical Processes** (2012)

# Modeling Conclusions & Future Work

- **Conclusions**
  - **MR model integrated into IGCC process model in MATLAB**
  - **Simulation and optimization studies for IGCC-MR plant performed**
    - **simulation results indicated successful nominal case**
    - **novel constrained optimization problem formulated and solved**
  - **Techno-economic assessment of IGCC-MR process completed (MATLAB)**
  - **MR cost analysis showed break even costs within feasible range**
- **Future work (Aspen)**
  - **Carry out simulation studies for different flowsheet alternatives**
  - **Perform techno-economic analysis using integrated model**

# Acknowledgements

U.S. Department of Energy (DOE) (grant DE-09FE0001322).

The University of Minnesota Characterization Facility, which receives partial support from NSF through the National Nanotechnology Infrastructure Network.